

8 7 6 5 4 3 2 1

D  
C  
B  
A

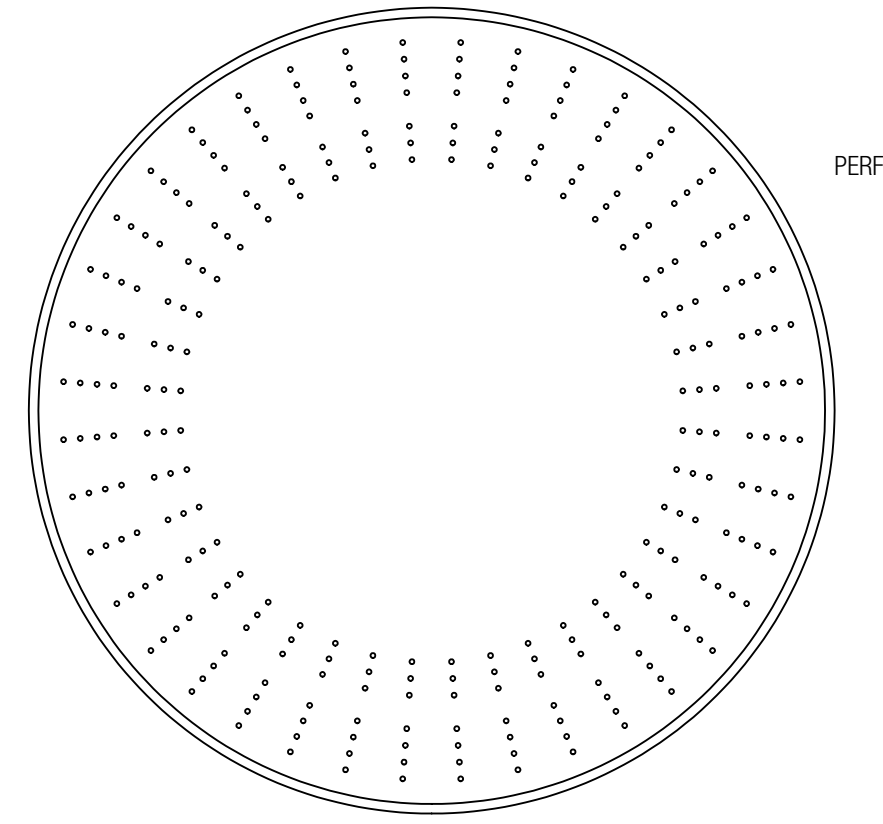
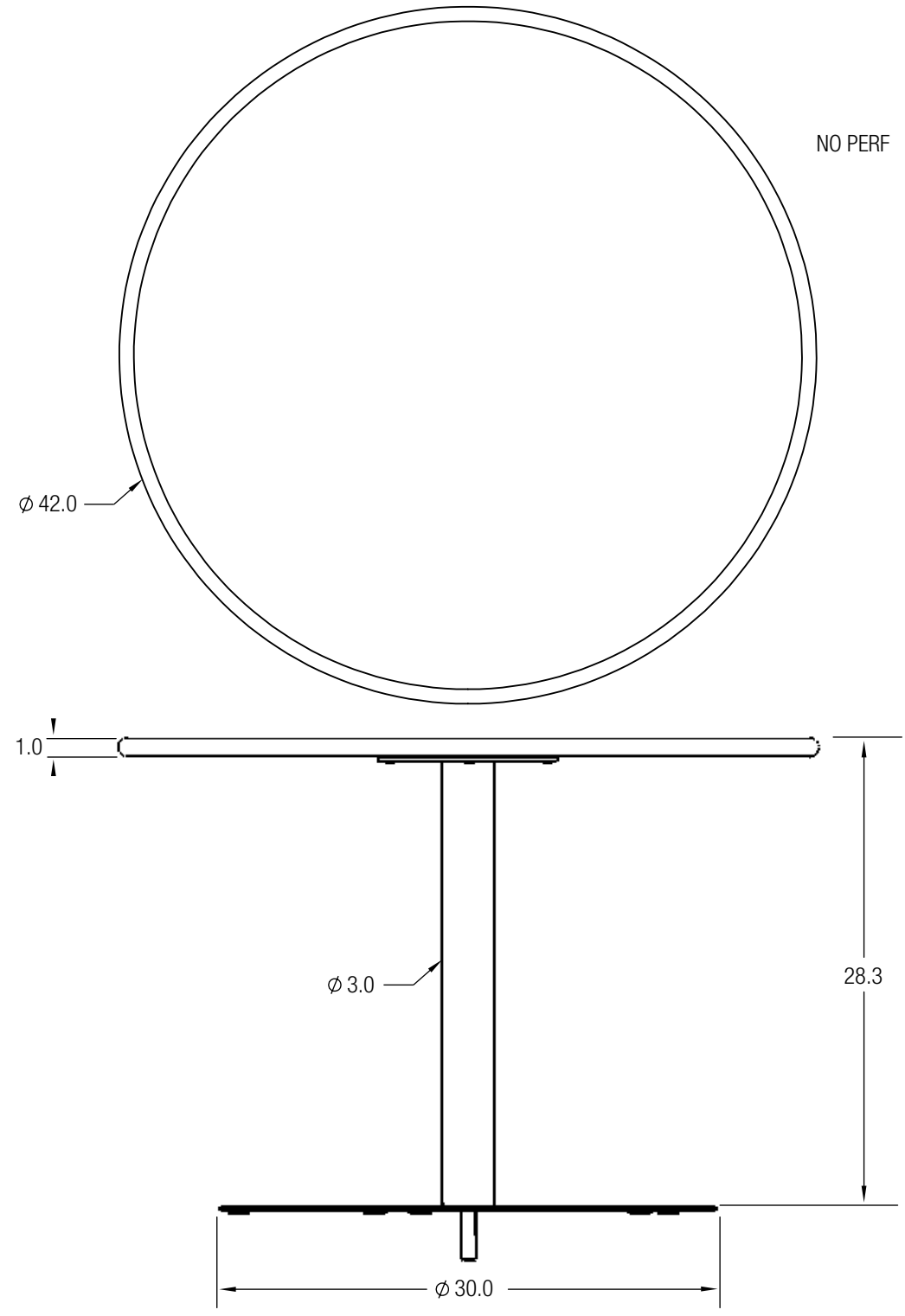

CUSTOMER APPROVAL:

X \_\_\_\_\_

DATE:

X \_\_\_\_\_

UNLESS OTHERWISE SPECIFIED, DIMENSIONS ARE IN INCHES

**FORMS+SURFACES**® 30 Pine Street, Pittsburgh, PA 15223  
Tel (800) 451-0410 Fax (412) 781-7840

TOLERANCES (UNLESS OTHERWISE SPECIFIED):  
 FRACTIONAL:  $\pm 1/32$   
 ANGULAR/BEND:  $\pm 1^\circ$   
 TWO PLACE DECIMAL  $\pm .030$   
 THREE PLACE DECIMAL  $\pm .020$

MATERIAL: SEE DATA SHEET

FINISH: SEE DATA SHEET

WEIGHT: 89 LBS

SOURCE: MDW

SCALE: N.T.S.

DWN	EK	DATE
		11/20/2013

DO NOT SCALE DRAWING

PROPRIETARY AND CONFIDENTIAL

THE INFORMATION CONTAINED IN THIS DRAWING IS THE SOLE PROPERTY OF FORMS + SURFACES. ANY REPRODUCTION IN PART OR AS A WHOLE WITHOUT WRITTEN PERMISSION IS PROHIBITED.

SIZE	DWG. NO.	REV	SHEET
B	SPCOL-T30R42	0	1 OF 1

COLUMN TABLE, TABLE HEIGHT (STAINLESS STEEL TABLE TOP - 42" ROUND ONLY), 30" BASE SPCOL-T30R42

8 7 6 5 4 3 2 1