









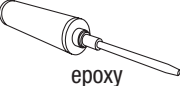

FACTOR™ TABLE

SURFACE MOUNT INSTALLATION INSTRUCTIONS

INCLUDED	MOUNTING KIT (SOLD SEPARATELY)			TOOLS NEEDED		
<p>a </p> <p>b </p>	<p> 7/32" hex bit for tamper-resistant bolts</p> <p> 5/32" hex bit for tamper-resistant bolts</p> <p> epoxy</p>	c 	d 	<p> pencil</p> <p> 1/4", 1/2" & 3/4" drill bits for concrete</p>	<p> hammer drill</p>	<p> steel wire brush</p> <p> epoxy gun</p>

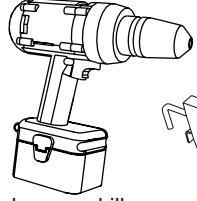
STEP BY STEP FOR ALL SURFACE MOUNTED FACTOR TABLES

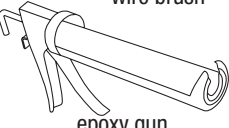
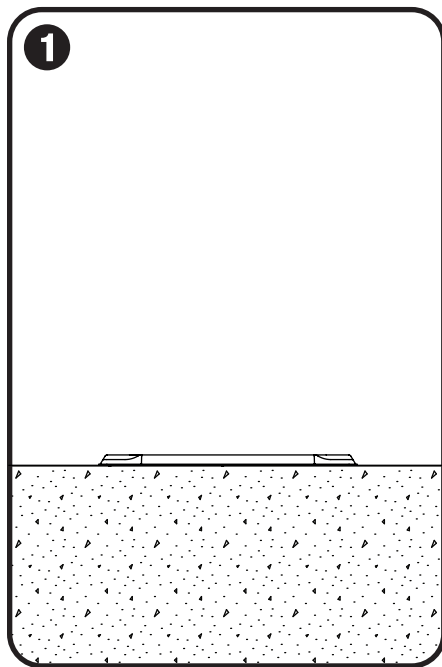

1 Place table top down

- Securely place table, top down, on top of a padded surface.

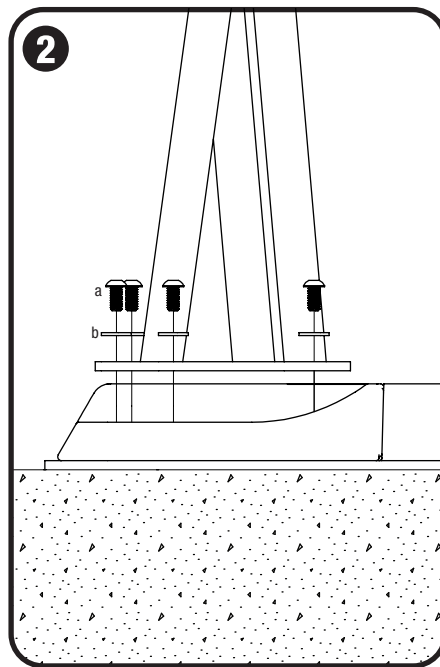

2 Attach legs

- Position leg so holes in plate line up with holes in table top. Ensure legs with surface mount plate are on opposite corners of the table.
- Slide 1/4" stainless steel flat washer (b) onto each 1/4"-20 x 1/2" tamper resistant button head cap bolt (a) using 5/32" hex bit for tamper-resistant bolts.
- Insert bolts into holes on leg and table top to secure legs to frame.

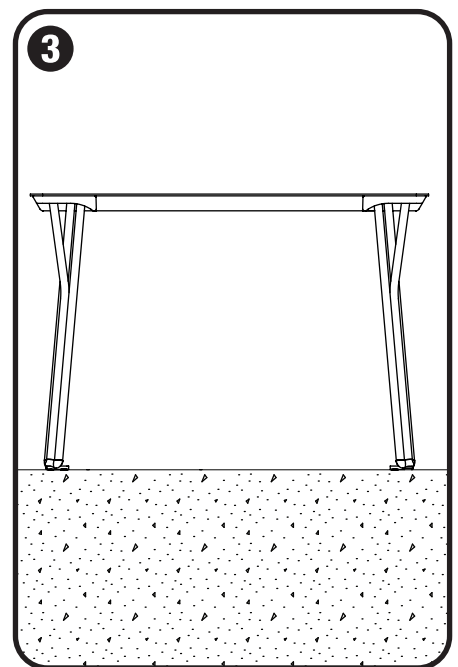

3 Mark hole locations

- Carefully turn table right side up; use padding where necessary.
- Position table in desired location. Mark center of both hole locations with pencil.

FACTOR™ TABLE

SURFACE MOUNT INSTALLATION INSTRUCTIONS

STEP BY STEP FOR ALL SURFACE MOUNTED FACTOR TABLES

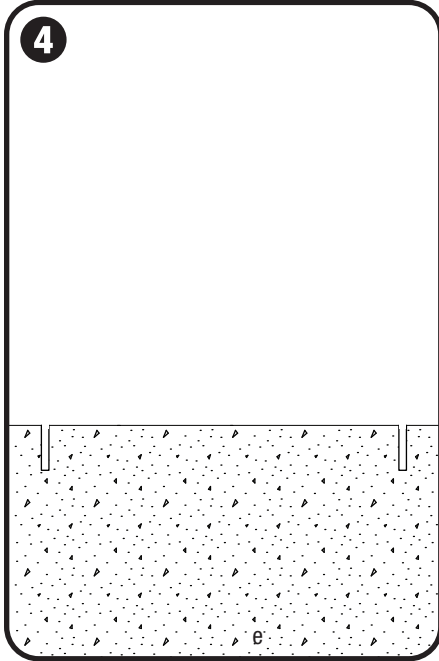

Drill holes

- Use hammer drill to drill 4.5" deep x 3/4" diameter anchor hole at each marked location using a 3/4" drill bit suitable for concrete drilling.

Note: Forms+Surfaces recommends starting with 1/4" diameter drill bit followed by 1/2" and finally 3/4" for maximum accuracy.

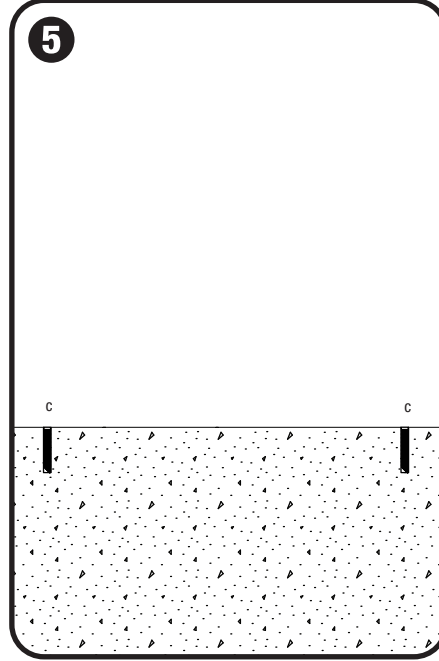

Fill holes & insert anchors

- Use compressed air and steel wire brush to clean each anchor hole in accordance with epoxy instructions.
- Use epoxy in epoxy gun to fill each anchor hole 5/8 of the hole depth in accordance with epoxy instructions.
- Insert 3/8"-16 x 4-1/4" epoxy anchor (c) into each anchor hole so anchor top is flush with ground. Allow proper curing time according to cure schedule on epoxy instructions before moving on to Step 6.

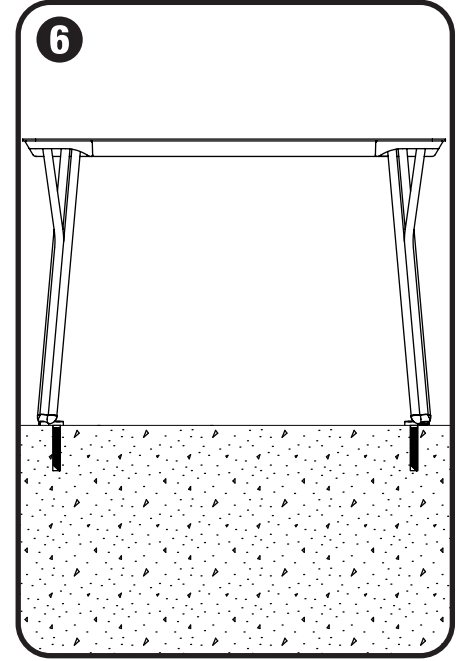

Position table

- Position table so that mounting holes line up with anchors.

FACTOR™ TABLE

STEP BY STEP FOR ALL SURFACE MOUNTED FACTOR TABLES

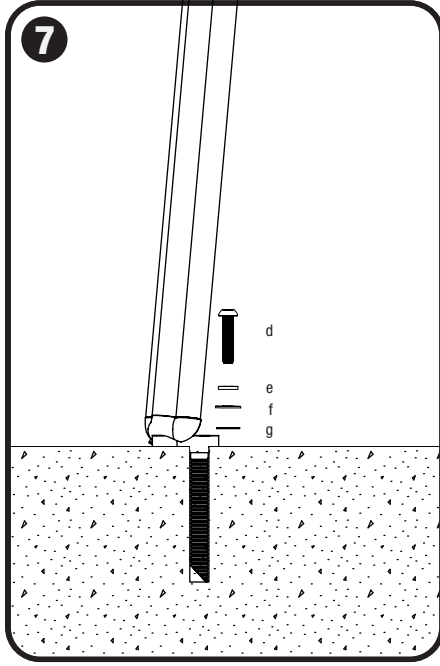

Attach table

- Slide 3/8" stainless steel lock washer (e), 3/8" stainless steel flat washer (f), and 3/8" nylon flat washer (g) onto each 3/8"-16 x 1-1/2" tamper-resistant button head cap bolt (d).
- Insert bolts into mounting holes in table and thread into anchors using 7/32" hex bit for tamper-resistant bolts.

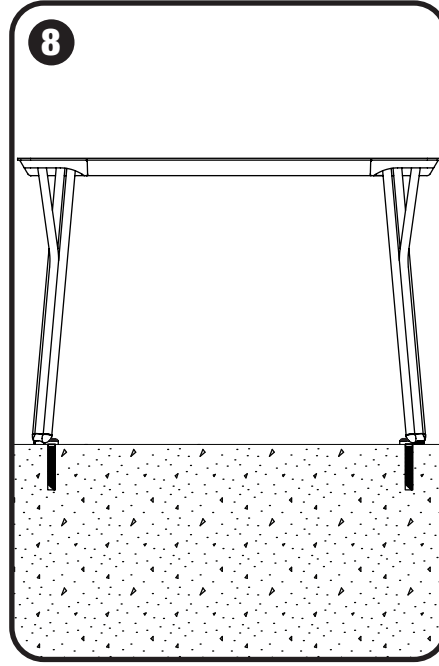

Tighten bolts

- Tighten bolts until snug.