

DUO™ TABLES & ENSEMBLES

SURFACE MOUNT INSTALLATION INSTRUCTIONS

MOUNTING KIT (SOLD SEPARATELY. ONE KIT PER BENCH OR TABLE)

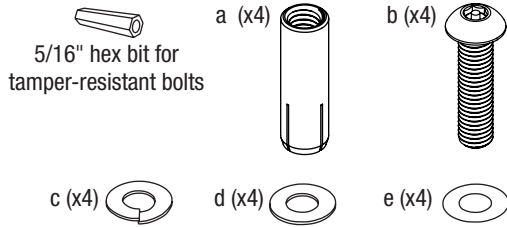

TOOLS NEEDED

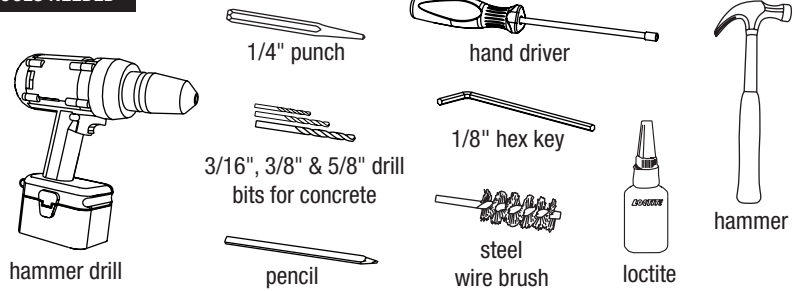

STEP BY STEP FOR ALL SURFACE MOUNTED DUO TABLES & ENSEMBLES

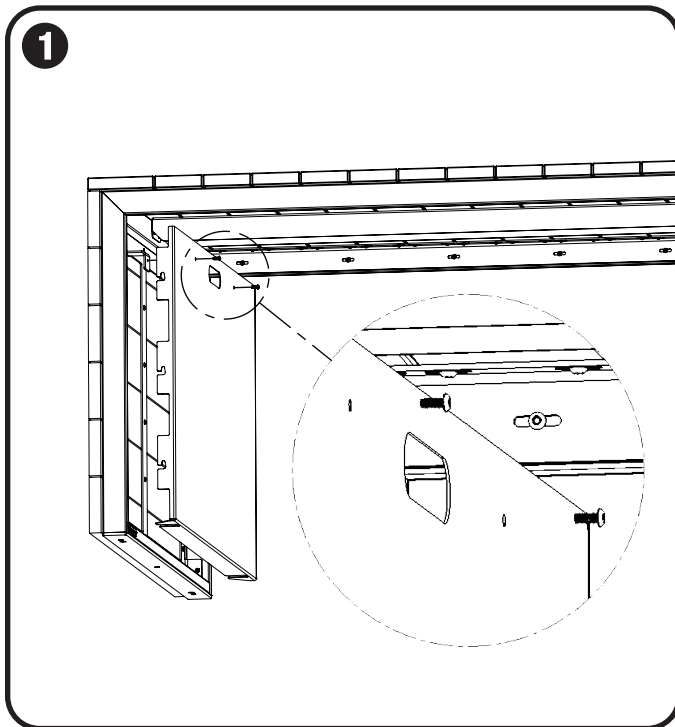

Remove waterfall leg cover panel from table

- Using 1/8" hex key, remove (2) 10-24 x 1/2" screws located at top of waterfall leg cover panel.
- Use the handle at the top of the waterfall leg panel to lift panel up and out. Set the (2) screws and panel aside.

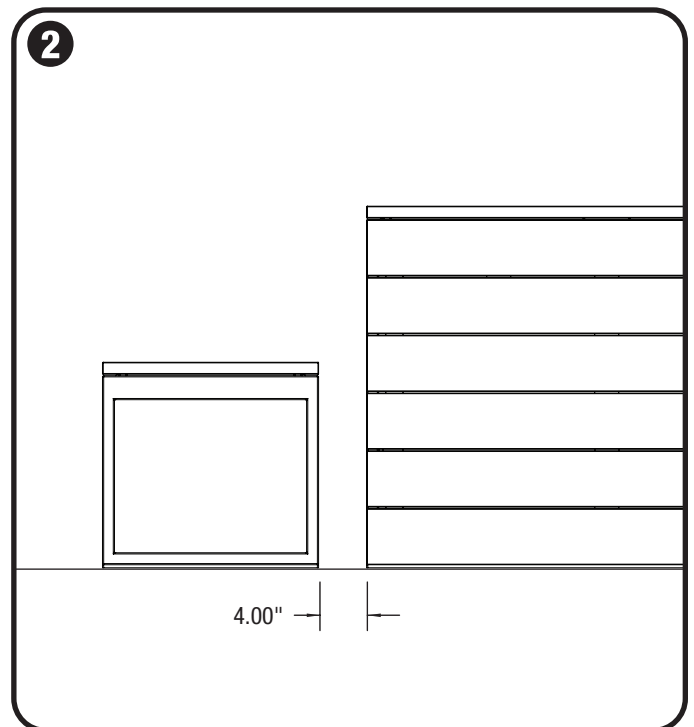

Mark hole locations

- Place table and benches (if included) in desired location. Mark center of each hole location with a pencil.
- The recommended distance between the table frame and bench frames is 4" for ensembles.

DUO™ TABLES & ENSEMBLES

SURFACE MOUNT INSTALLATION INSTRUCTIONS

STEP BY STEP FOR ALL SURFACE MOUNTED DUO TABLES & ENSEMBLES

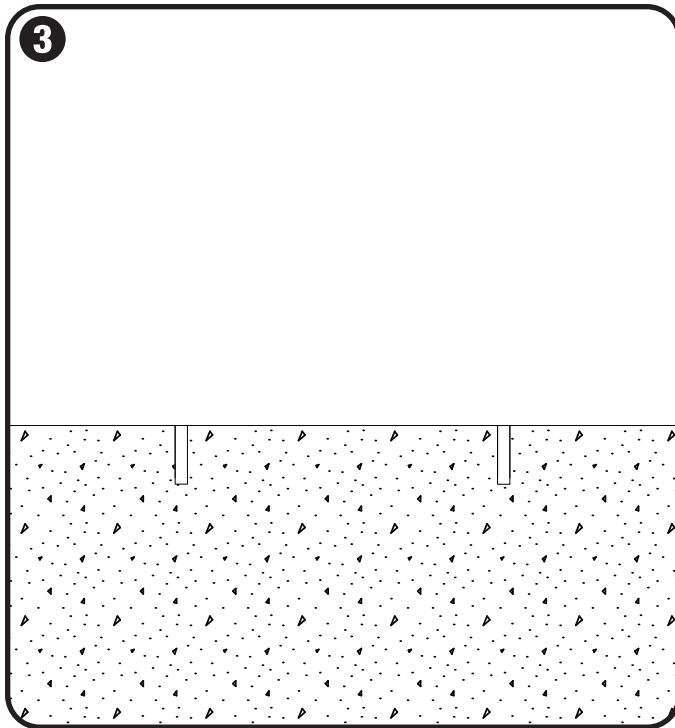

Drill holes

- Use hammer drill to drill 2-1/4" deep x 5/8" diameter anchor hole at each marked location using a 5/8" drill bit suitable for concrete drilling.

NOTE: Forms+Surfaces recommends starting holes with 3/16" diameter drill bit followed by 3/8" and finally 5/8" for maximum accuracy.

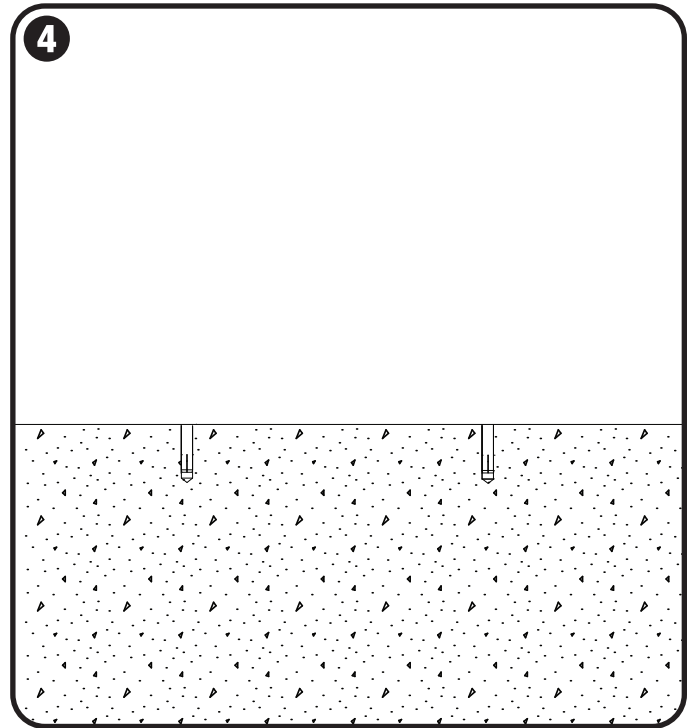

Insert & set anchors

- Use compressed air and steel wire brush to clean each anchor hole.
- Insert 1/2"-13 x 2" anchor (a) into each anchor hole and use hammer to tap anchor tops flush with ground level.
- Use 1/4" punch and hammer to set anchors by driving down the center of each anchor until it stops.

DUO™ TABLES & ENSEMBLES

SURFACE MOUNT INSTALLATION INSTRUCTIONS

STEP BY STEP FOR ALL SURFACE MOUNTED DUO TABLES & ENSEMBLES

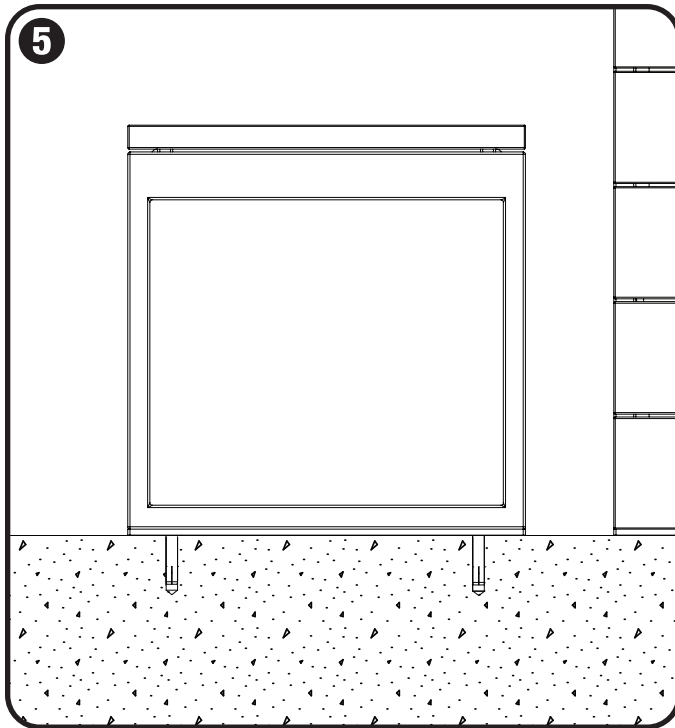

Position furniture

- Position tables and benches (if using) so that mounting holes line up with anchors.

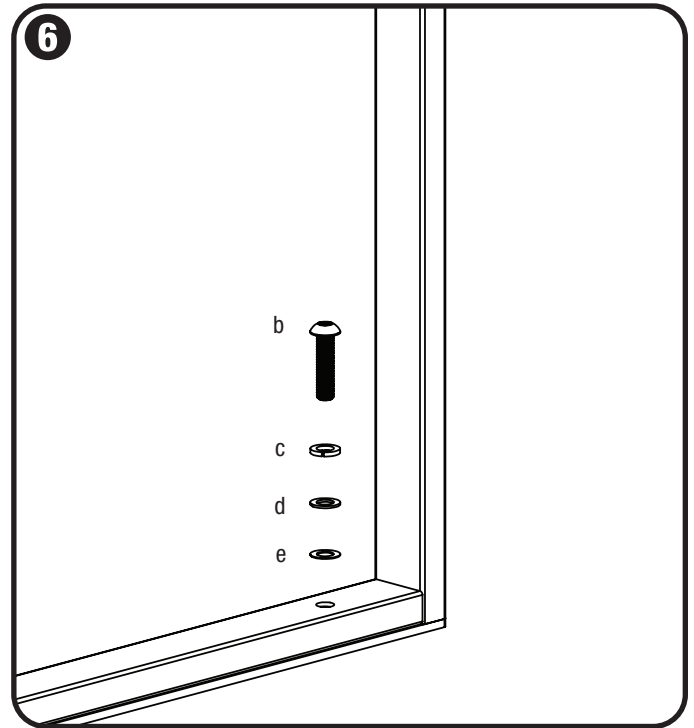

Attach table and benches (if included)

- Slide 1/2" stainless steel lock washer (c), then 1/2" stainless steel flat washer (d) and 1/2" nylon flat washer (e) onto each 1/2"-13 x 2" tamper-resistant button head cap bolt (b).
- Insert bolts into mounting holes in bench and thread into anchors by hand.
- Repeat for each anchor point.

DUO™ TABLES & ENSEMBLES

SURFACE MOUNT INSTALLATION INSTRUCTIONS

STEP BY STEP FOR ALL SURFACE MOUNTED DUO TABLES & ENSEMBLES

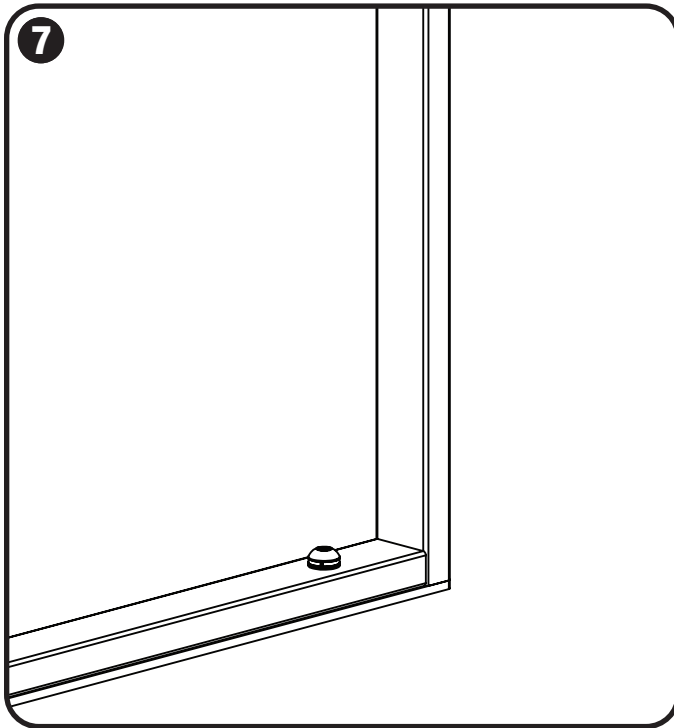

Tighten bolts

- Using 5/16" hex bit for tamper-resistant bolts and hand driver or non-impact drill on low-torque setting, tighten screws until snug.
- Repeat for each anchor point.

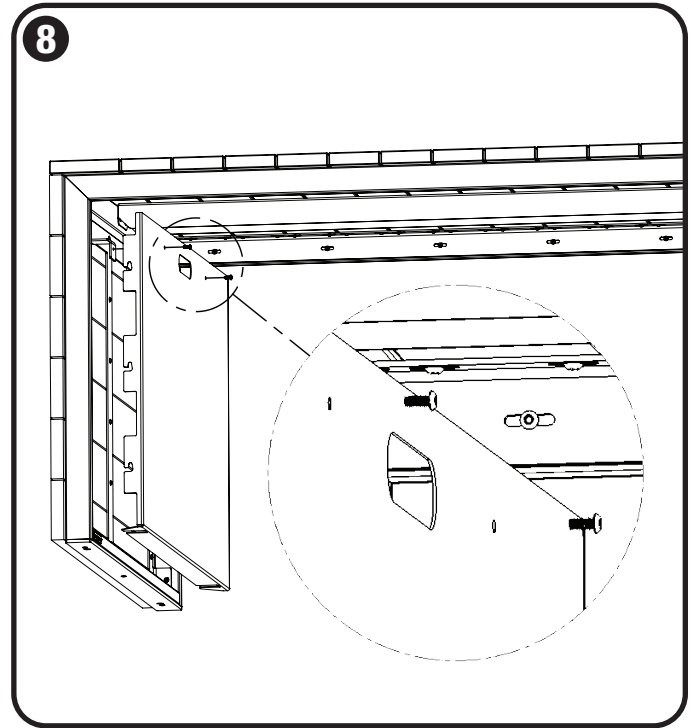

Reinstall waterfall leg cover panel to table

- Using handle at top, insert waterfall leg cover panel into leg and push down to engage hooks.
- Using 1/8" hex key, reinstall (2) 10-24 x 1/2" screws located at top of waterfall leg cover panel. Applying Loctite® Blue 242 or similar thread locker on screw threads is recommended.