

DUO™ BENCH

SURFACE MOUNT INSTALLATION INSTRUCTIONS

MOUNTING KIT (SOLD SEPARATELY)

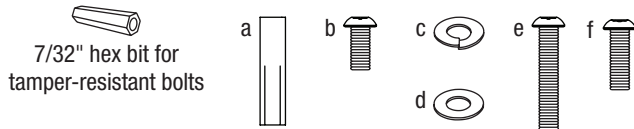

TOOLS NEEDED



STEP BY STEP FOR ALL SURFACE MOUNTED DUO BENCHES

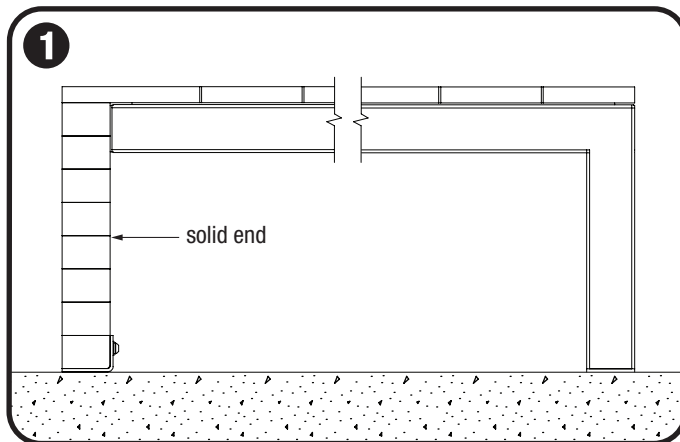

1 Mark location of solid end

- Place bench in desired location. Trace around the mounting bracket under the solid end of the bench with a pencil.

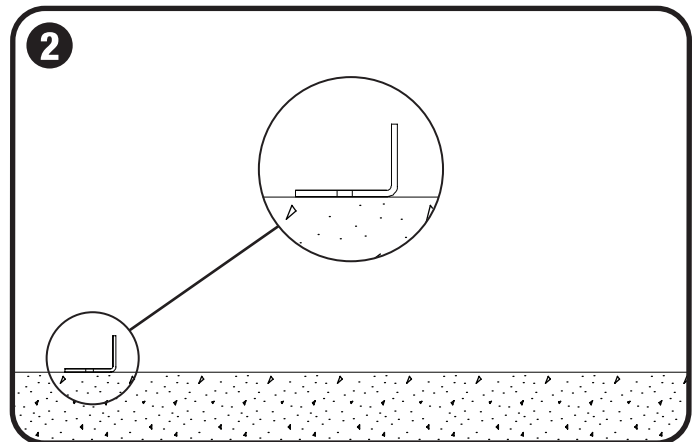

2 Remove mounting bracket & mark hole locations

- Remove 3/8"-16 x 1" tamper-resistant cap bolts and washers from mounting bracket and remove mounting bracket from bench.
- Place bracket in marked location & mark hole locations with a pencil.

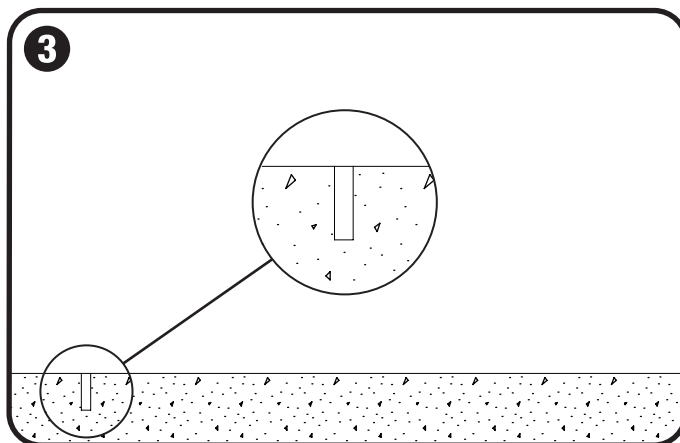

3 Drill holes

- Use hammer drill to drill 1-7/8" deep x 1/2" diameter anchor hole at each marked location using a 1/2" drill bit suitable for concrete drilling.

NOTE: Forms+Surfaces recommends starting holes with 3/16" diameter drill bit followed by 3/8" and finally 1/2" for maximum accuracy.

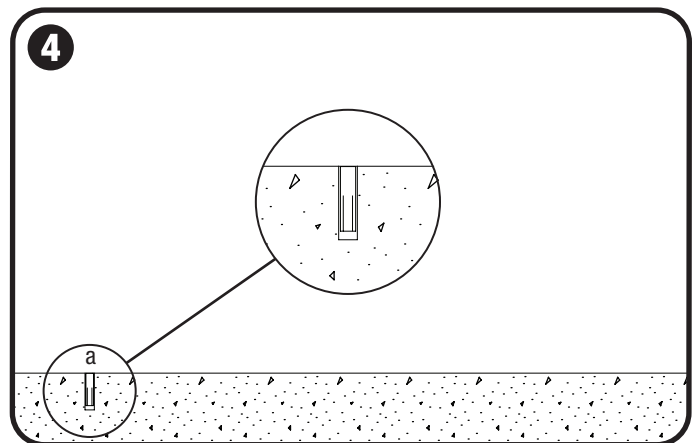

4 Insert & set anchors

- Use compressed air and steel wire brush to clean each anchor hole.
- Insert 3/8"-16 x 1-1/2" anchor (a) into each anchor hole and use hammer to tap anchor tops flush with ground level. Use 1/4" punch and hammer to set anchors by driving down the center of each anchor until it stops.

DUO™ BENCH

SURFACE MOUNT INSTALLATION INSTRUCTIONS

STEP BY STEP FOR ALL SURFACE MOUNTED DUO BENCHES

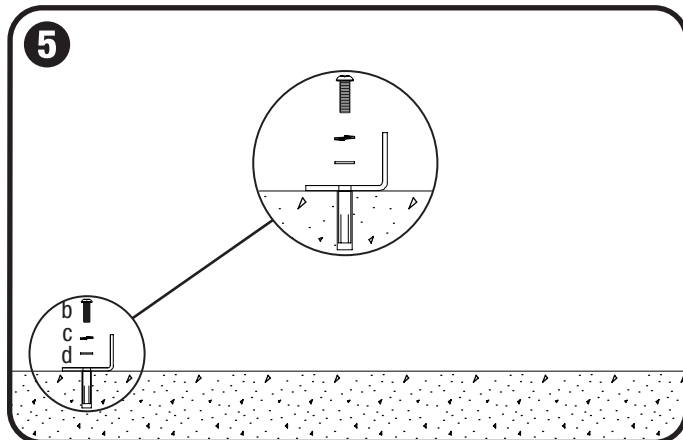

Attach corner bracket to ground

- Slide 3/8" stainless steel lock washer (c), then 3/8" stainless steel flat washer (d) onto each 3/8"-16 x 3/4" tamper-resistant button head cap bolt (b).
- Insert bolts into mounting holes in mounting bracket and thread into anchors using 7/32" hex bit for tamper resistant bolts.

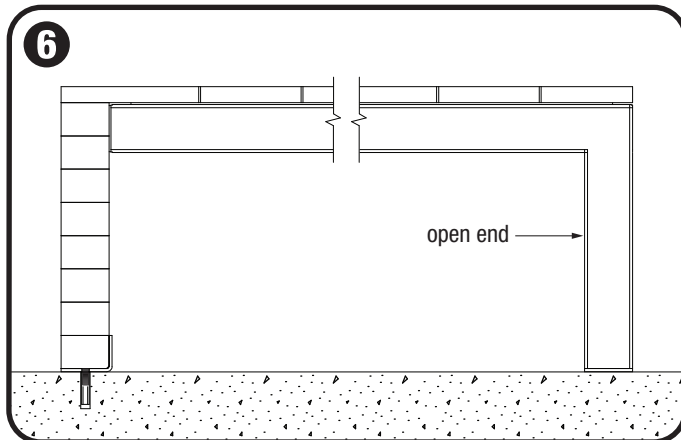

Place bench & mark hole locations in open end

- Place bench in original position, over mounting bracket.
- Mark center of each hole location in open end of bench with a pencil.

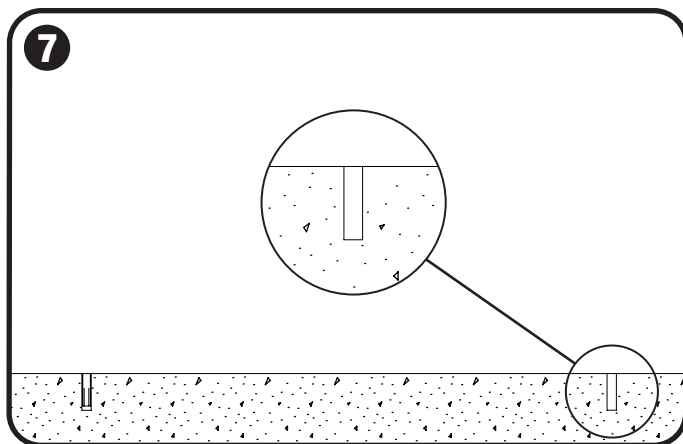

Drill holes

- Use hammer drill to drill 1-7/8" deep x 1/2" diameter anchor hole at each marked location using a 1/2" drill bit suitable for concrete drilling.

NOTE: Forms+Surfaces recommends starting holes with 3/16" diameter drill bit followed by 3/8" and finally 1/2" for maximum accuracy.

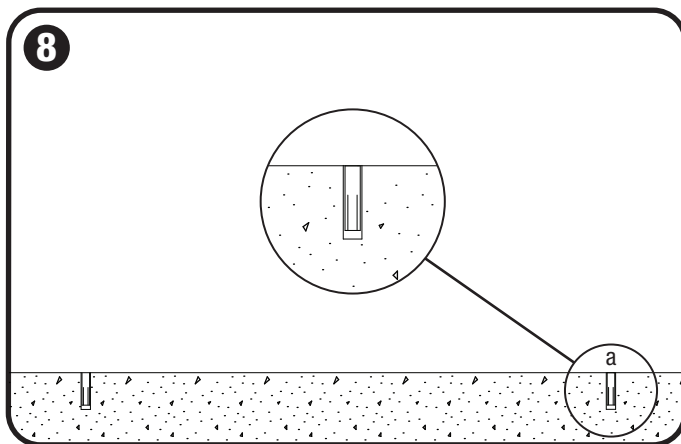

Insert & set anchors

- Use compressed air and steel wire brush to clean each anchor hole.
- Insert 3/8"-16 x 1-1/2" anchor (a) into each anchor hole and use hammer to tap anchor tops flush with ground level.
- Use 1/4" punch and hammer to set anchors by driving down the center of each anchor until it stops.

DUO™ BENCH

SURFACE MOUNT INSTALLATION INSTRUCTIONS

STEP BY STEP FOR ALL SURFACE MOUNTED DUO BENCHES

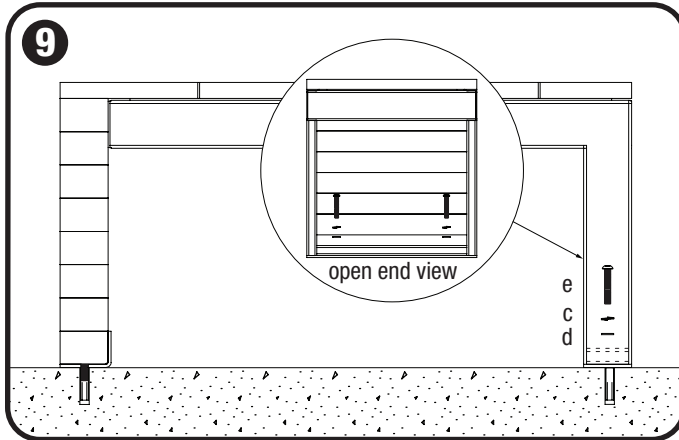

Attach bench to ground

- Place bench in original position, over corner bracket.
- Slide 3/8" stainless steel lock washer (c), then 3/8" stainless steel flat washer (d) onto each 3/8"-16 x 1-3/4" tamper-resistant button head cap bolt (e).
- Insert bolts into mounting holes in open end of bench and thread into anchors using 7/32" hex bit for tamper resistant bolts.

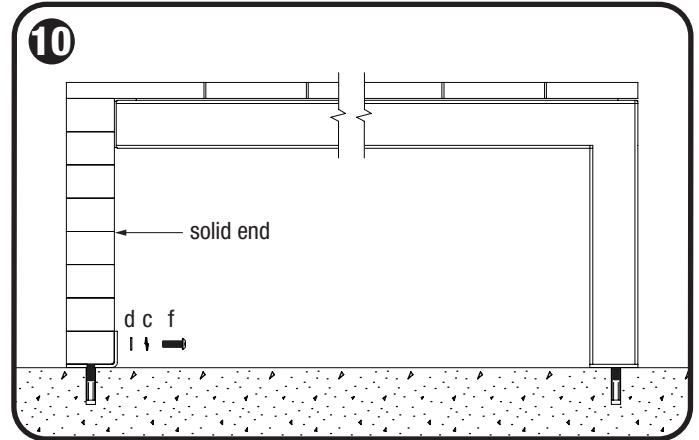

Attach bench to corner bracket

- Slide 3/8" stainless steel lock washer (c), then 3/8" stainless steel flat washer (d) onto each 3/8"-16 x 1" tamper-resistant button head cap bolt (f).
- Insert bolts into mounting holes in mounting bracket and thread into solid end of bench using provided 7/32" hex bit for tamper resistant bolts.